

MacArtney BMT-DR2 16-04 AHC Winch



MAGELLAN

MacArtney BMT-DR2 electrically driven winches provide a robust and advanced asset handling system, ensuring safe control of assets during all operational phases.

The BMT-DR2 is currently fitted with 7000m of Dynlce 34mm synthetic rope and offers excellent performance.

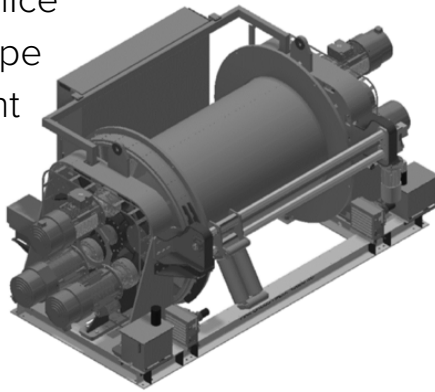

Features and benefits

Compact and modular design using standardised and ex-changeable components

Designed for easy integration with launch and recovery and moon pool handling systems

All structural components in painted carbon steel

Integrated protection frame and grating

Frame mounted main switchbox

Electrically driven level wind

Designed according to DNV's Standard for Lifting Appliances Certification note 2.22

Long and proven track record

Low noise operation

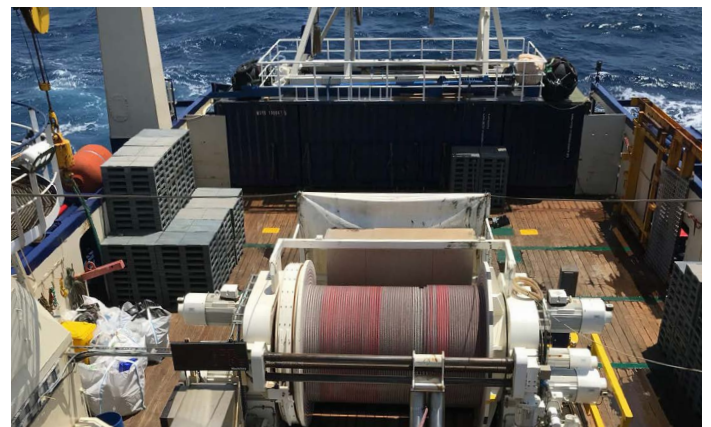

NOTE: Package configuration subject to change and will be customised for individual projects

1st Floor Tudor House
Le Bordage, St Peter Port
GY1 1DB, Guernsey

E: operations@magellan.gg
www.magellan.gg

MacArtney MERMAC R50 AHC Heave-Compensated Winch

Specifications

Winch

Weight (excluding rope)	34,000kg
Length	6802mm
Width	4272mm
Height	2987mm

Rope

Manufacturer	Hampidjan
Type	Dynlce 75
OD	34mm
Length	7000m
MBL	91T

Winch Performance

Bottom Layer | Low Speed

Force	300kN
Speed	0-75m/min

High Speed

Force	150kn
Speed	0-120m/min

Top Layer | Low Speed

Force	200kN
Speed	0-115m/min

High Speed

Force	100kN
Speed	0-115m/min

Rope Performance

Overall Diameter	34mm
Breaking Strength (unspliced)	91T
Weight In Air	0.710 kg/m
Weight in Sea Water	-0.057kg/m
Max working Temp	65°C

Winch dimensions standard setup

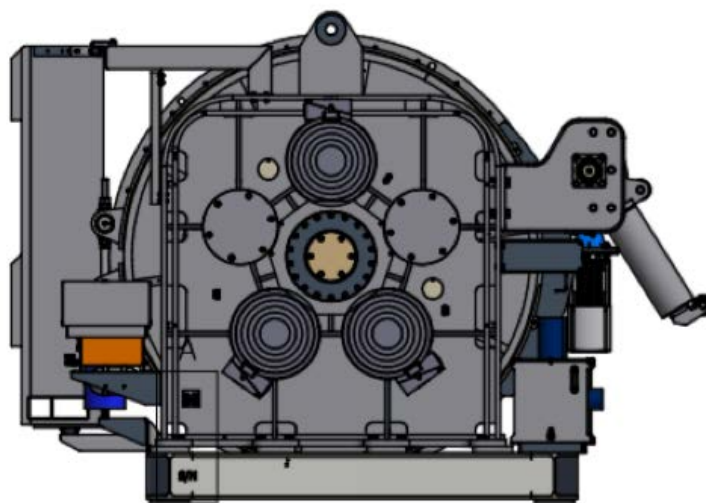
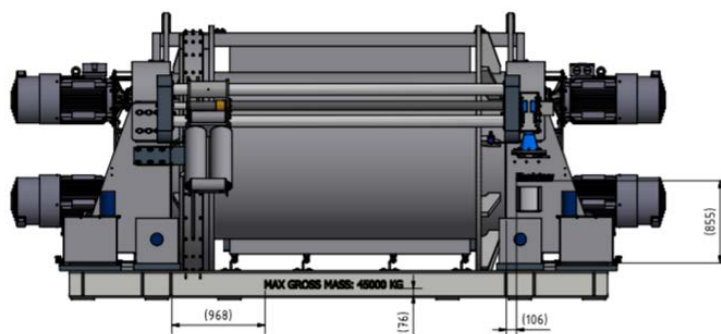

NOTE: Package configuration subject to change and will be customised for individual projects

1st Floor Tudor House
Le Bordage, St Peter Port
GY1 1DB, Guernsey

E: operations@magellan.gg
www.magellan.gg